

GUGLIELMI

MADE IN ITALY

LAVELLI IN ACCIAIO INOX E IN COMPOSITO STAINLESS STEEL AND COMPOSITE SINKS

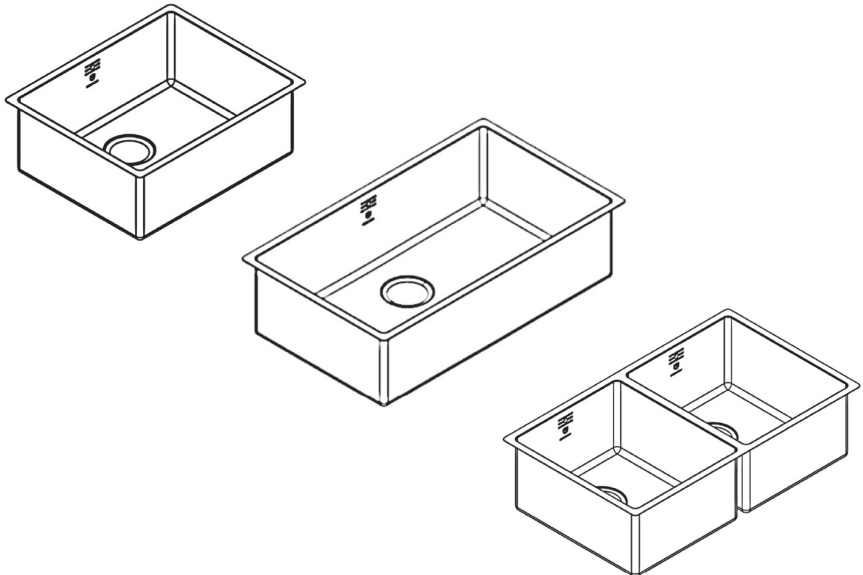

GRAZIE PER AVERCI SCELTO

Dal 1954 garantiamo per i nostri prodotti, realizzati interamente in Italia, l'assoluta qualità dei materiali ed un accurato controllo nelle diverse fasi della produzione. Vi auguriamo un piacevole utilizzo.

THANKS FOR CHOOSING US

Since 1954 we guarantee for our products, entirely made in Italy, the absolute quality of materials and an accurate control at each production stage. We wish you a pleasant use.

MERCI DE NOUS AVOIR CHOISIS

Depuis 1954 on garantit pour nos produits, réalisés entièrement en Italie, la qualité absolue des matériaux et un contrôle soigné de différentes phases de leur fabrication. On Vous souhaite une utilisation agréable.

DANKE, DASS SIE UNS GEWÄHLT HABEN

Seit 1954 garantieren wir bei unseren Produkten, die komplett in Italien hergestellt werden, die absolute Qualität der verwendeten Materialien sowie eine genaue Kontrolle in den verschiedenen Produktionsphasen. Wir wünschen Ihnen eine angenehme Verwendung.

GRACIAS PARA CONFIAR EN NOSOTROS

Desde 1954 garantizamos para nuestros productos, realizados totalmente en Italia, la absoluta calidad de los materiales y un riguroso control en las diferentes fases de producción. Os deseamos un buen uso.

INFORMAZIONI TECNICHE TECHNICAL INFORMATION

VI81520

con piletta integrata *with integrated drain*

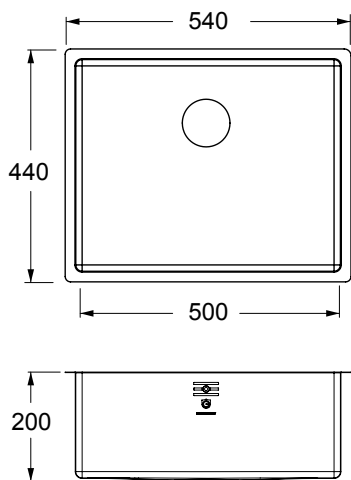

COMPATIBILE CON KIT PILETTA*
COMPATIBLE WITH DRAIN KIT

CO10546



* venduto separatamente *sold separately*

VI81510 - VC90510

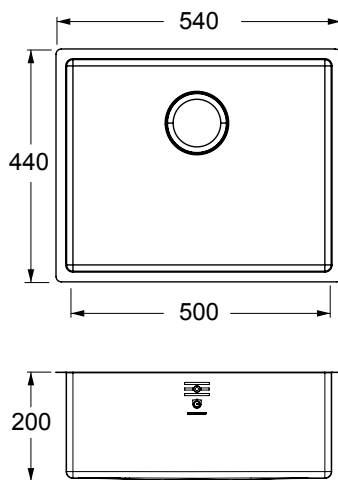

COMPATIBILE CON KIT PILETTA*
COMPATIBLE WITH DRAIN KIT

CO10537



Il contenuto delle scatole può variare in base all'articolo.
The box content may vary depending on the article.

Non inclusi
Not included

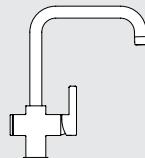

VI81520 - VI81510 - VC90510

FILOTOP
FLUSHMOUNT



INCASSO
BUILT-IN

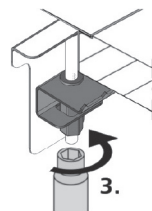
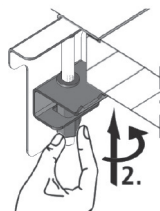
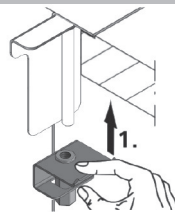
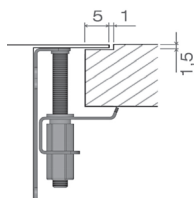
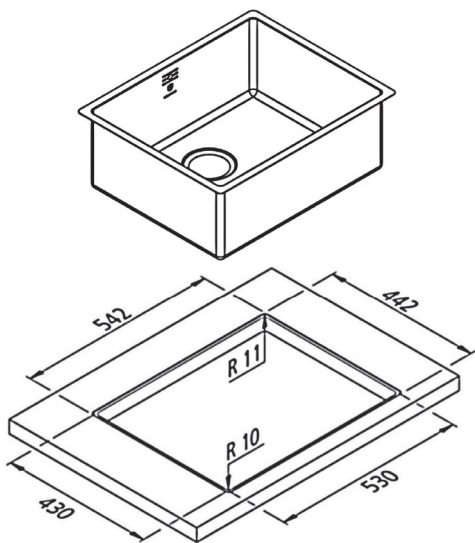

SOTTOTOP
UNDERMOUNT

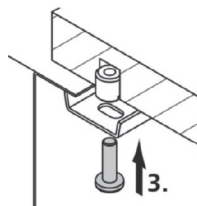
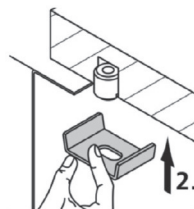
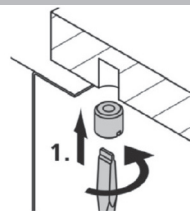
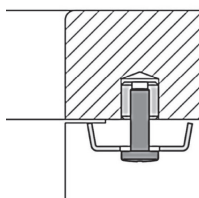
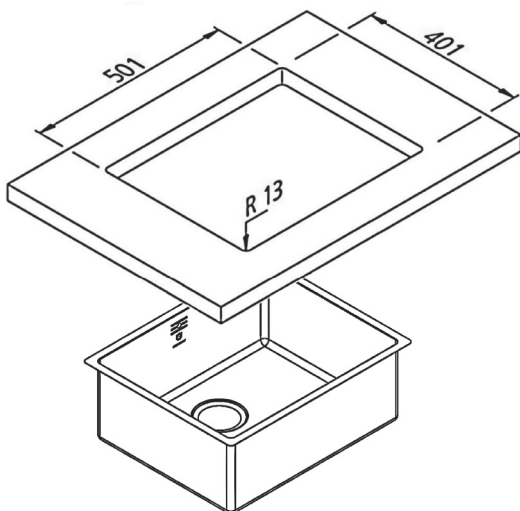

INFORMAZIONI TECNICHE TECHNICAL INFORMATION

VI81620

con piletta integrata *with integrated drain*

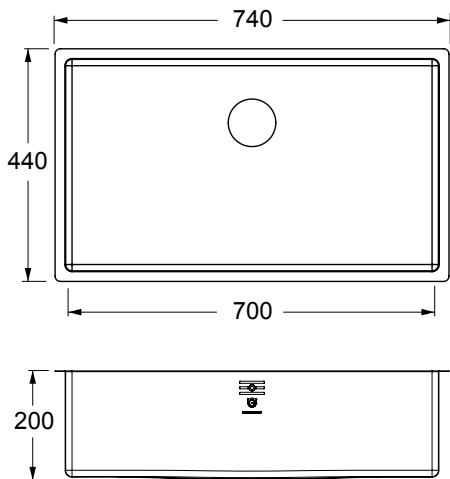

COMPATIBILE CON KIT PILETTA*
COMPATIBLE WITH DRAIN KIT

CO10546



* venduto separatamente *sold separately*

VC90610

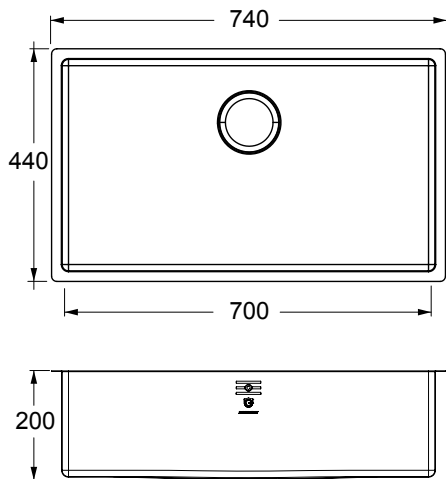

COMPATIBILE CON KIT PILETTA*
COMPATIBLE WITH DRAIN KIT

CO10537



Il contenuto delle scatole può variare in base all'articolo.
The box content may vary depending on the article.

Non inclusi
Not included

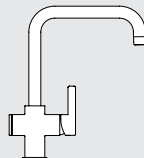

VI81620 - VC90610

FILOTOP
FLUSHMOUNT



INCASSO
BUILT-IN

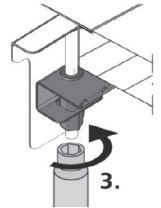
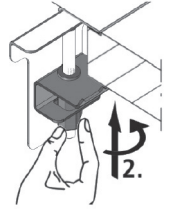
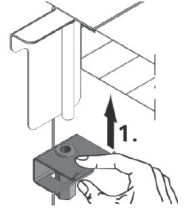
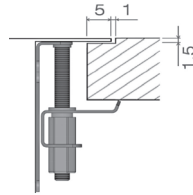
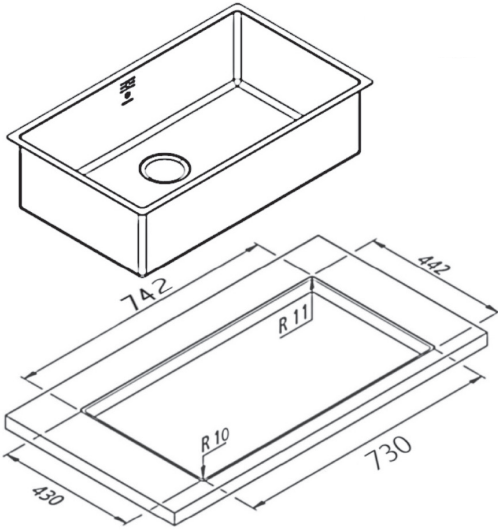

SOTTOTOP
UNDERMOUNT

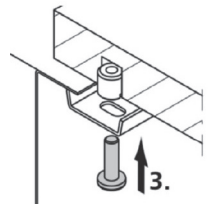
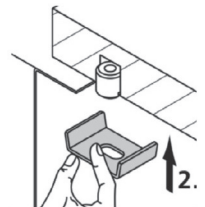
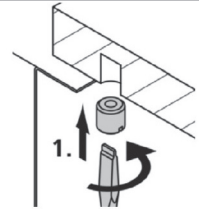
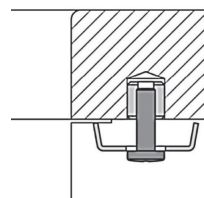
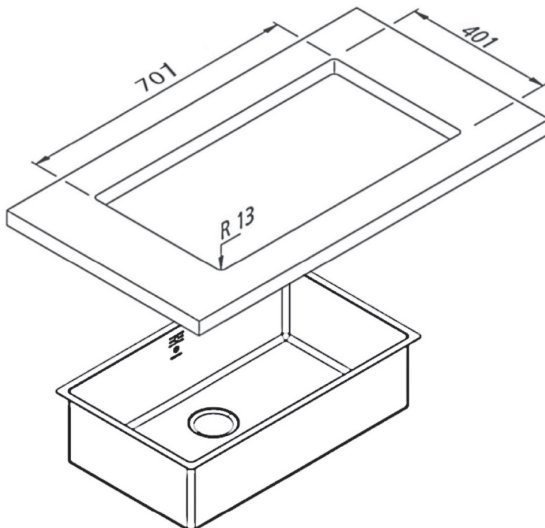

INFORMAZIONI TECNICHE TECHNICAL INFORMATION

VI81720

con piletta integrata *with integrated drain*

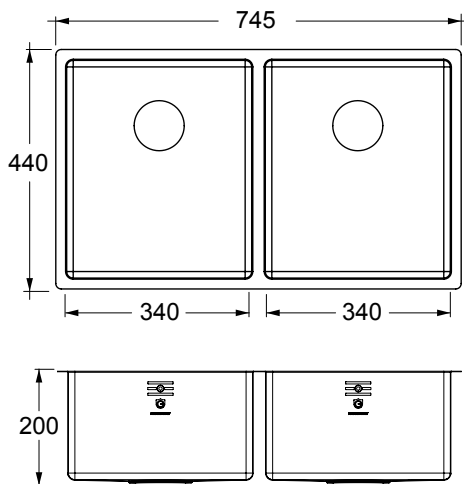

COMPATIBILE CON KIT PILETTA*
COMPATIBLE WITH DRAIN KIT



CO10547

SIFONE SALVASPAZIO*
SAVE SPACE SIPHON

compatibile con tutti i nostri lavelli
compatible with all our sinks



CO10538

* venduto separatamente *sold separately*



Il contenuto delle scatole può variare in base all'articolo.
The box content may vary depending on the article.

Non inclusi
Not included

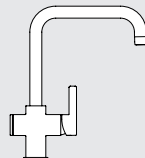

VI81720

FILOTOP
FLUSHMOUNT



INCASSO
BUILT-IN

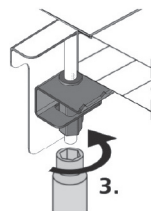
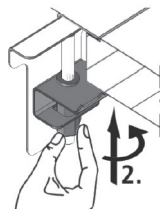
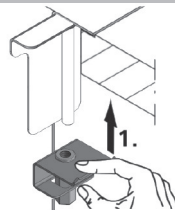
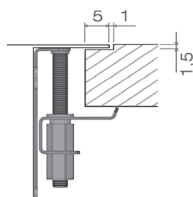
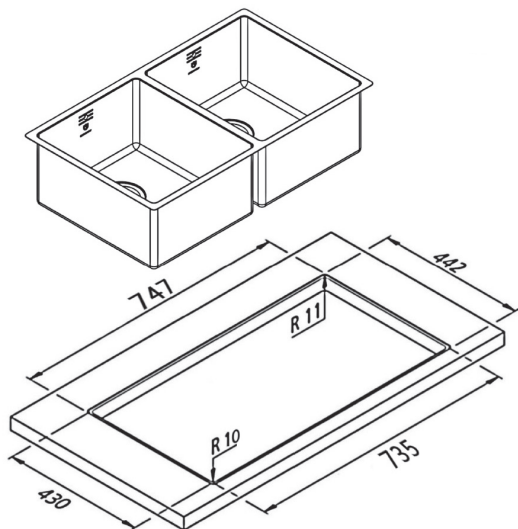

SOTTOTOP
UNDERMOUNT

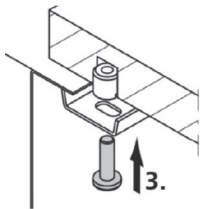
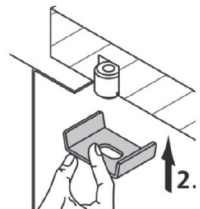
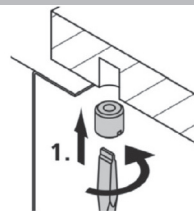
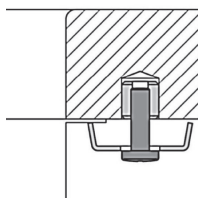
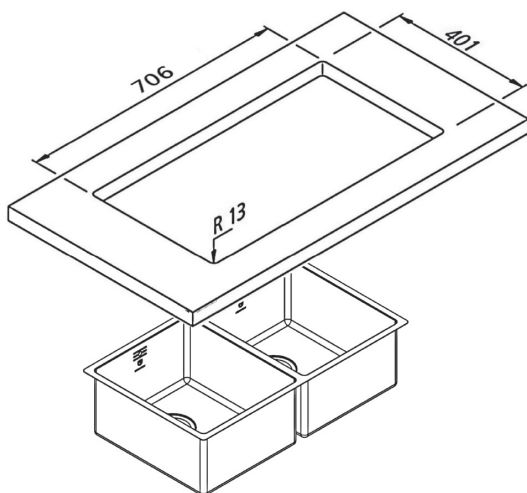

ACCESSORI VASCHE SINKS ACCESSORIES



AC81910

Vaschetta forata in acciaio inox
Stainless steel perforated tray



AC81920

Colatoio in acciaio inox
Stainless steel colander



AC81960

Tagliere in legno di iroko
Iroko wood cutting board



AC81970

Tagliere nero in HPE
HPE black cutting board

GARANZIA

I nostri prodotti sono garantiti per un periodo di 2 anni per imperfezioni di fabbricazione o relative alla superficie, a condizione che siano stati installati in conformità con il manuale di installazione.

Il reclamo dovrà pervenire in conformità con i termini e le condizioni di garanzia applicabili.

La garanzia non è valida per danni causati da uso improprio, danni intenzionali o accidentali, danni causati da negligenza, trasporto, normale usura, segni o graffi causati da urti, riparazioni errate e/o eseguite da personale non autorizzato, danni causati da una manutenzione o pulizia improprie (compreso l'uso di prodotti chimici o di detergenti contenenti agenti corrosivi). Qualsiasi prodotto, o parte di esso, che sia stato riparato o alterato senza autorizzazione scritta da parte dell'azienda, invaliderà la garanzia.

WARRANTY

Our products are guaranteed for a period of 2 years against manufacturing or surface imperfections, provided that they have been installed in accordance with the installation manual.

Claims must be made in accordance with the applicable warranty terms and conditions.

The warranty does not apply to damage caused by misuse, intentional or accidental damage, damage caused by negligence, transportation, normal wear and tear, marks or scratches caused by shock, incorrect repairs and/or repairs carried out by unauthorised personnel, damage caused by improper maintenance or cleaning (including the use of chemicals or detergents containing corrosive agents). Any product, or part thereof, that has been repaired or altered without written permission from the company will void the warranty.

GARANTIE

Nos produits sont garantis pour une période de 2 ans pour les imperfections de fabrication ou de surface, à condition qu'ils aient été installés conformément à la notice d'installation.

La plainte doit être reçue conformément aux conditions de garantie applicables.

La garantie n'est pas valable pour les dommages causés par une utilisation incorrecte, les dommages intentionnels ou accidentels, les dommages causés par la négligence, le transport, l'usure normale, les marques ou rayures causées par des chocs, les réparations incorrectes et/ou les réparations effectuées par du personnel non autorisé, les dommages causés par d'entretien ou de nettoyage incorrects (y compris l'utilisation de produits chimiques ou de détergents contenant des agents corrosifs).

Tout produit, ou une partie de celui-ci, qui a été réparé ou modifié sans l'autorisation écrite de la société, annulera la garantie.

GEWÄHRLEISTUNG

Auf unsere Produkte gewähren wir 2 Jahre Garantie auf Herstellungs- oder Oberflächenfehler, sofern sie gemäß der Montageanleitung installiert wurden.

Die Reklamation muss gemäß den geltenden Garantiebedingungen eingehen.

Die Garantie gilt nicht für Schäden, die durch Missbrauch, vorsätzliche oder versehentliche Beschädigung, durch Fahrlässigkeit verursachte Schäden, Transport, normale Abnutzung, durch Stöße verursachte Flecken oder Kratzer, unsachgemäße Reparaturen und / oder Reparaturen durch nicht autorisiertes Personal, Schäden durch unsachgemäße Wartung oder Reinigung (einschließlich der Verwendung von Chemikalien oder Reinigungsmitteln, die ätzende Mittel enthalten).

Jedes Produkt oder Teile davon, das ohne schriftliche Genehmigung des Unternehmens repariert oder geändert wurde, führt zum Erlöschen der Garantie.

GARANTIA

Nuestros productos tienen una garantía de 2 años contra defectos de fabricación o de superficie, siempre que se hayan instalado de acuerdo con el manual de instalación.

Las reclamaciones deben realizarse de acuerdo con las condiciones de garantía aplicables.

La garantía no se aplica a los daños causados por el mal uso, los daños intencionados o accidentales, los daños causados por negligencia, el transporte, el desgaste normal, las marcas o arañazos causados por golpes, las reparaciones incorrectas y/o las reparaciones realizadas por personal no autorizado, los daños causados por un mantenimiento o una limpieza inadecuados (incluido el uso de productos químicos o detergentes que contengan agentes corrosivos). Cualquier producto, o parte del mismo, que haya sido reparado o alterado sin el permiso escrito de la empresa, anulará la garantía.

